



**FEATURES:**

- Over Voltage Protection
- Wide 4:1 input range
- High efficiency up to 88%
- Over current Protection
- Very low no load power consumption of 0.12W
- Input / Output Isolation 1500, 3000 & 6000VDC
- Under voltage lockout
- Continuous short circuit protection



**Models**  
**Single output**

Model	Input Voltage (V)	Output Voltage (V)	Output Current max (mA)	Max. Capacitive Load (µF)	Isolation (VDC)	Efficiency (%)
AM6TW-2403S-NZ	9-36	3.3	1500	1800	1500	79
AM6TW-2405S-NZ	9-36	5	1200	1000	1500	83
AM6TW-2412S-NZ	9-36	12	500	470	1500	87
AM6TW-2415S-NZ	9-36	15	400	220	1500	88
AM6TW-2424S-NZ	9-36	24	250	100	1500	87
AM6TW-4803S-NZ	18-75	3.3	1500	1800	1500	80
AM6TW-4805S-NZ	18-75	5	1200	1000	1500	84
AM6TW-4812S-NZ	18-75	12	500	470	1500	87
AM6TW-4815S-NZ	18-75	15	400	220	1500	88
AM6TW-4824S-NZ	18-75	24	250	100	1500	87
AM6TW-2403SH30-NZ	9-36	3.3	1500	2200	3000	79
AM6TW-2405SH30-NZ	9-36	5	1200	2200	3000	83
AM6TW-2412SH30-NZ	9-36	12	500	680	3000	88
AM6TW-2415SH30-NZ	9-36	15	400	470	3000	88
AM6TW-2424SH30-NZ	9-36	24	250	330	3000	87
AM6TW-4803SH30-NZ	18-75	3.3	1500	2200	3000	79
AM6TW-4805SH30-NZ	18-75	5	1200	2200	3000	83
AM6TW-4812SH30-NZ	18-75	12	500	680	3000	88
AM6TW-4815SH30-NZ	18-75	15	400	470	3000	88
AM6TW-4824SH30-NZ	18-75	24	250	330	3000	87
AM6TW-2405SH60-NZ	9-36	5	1200	2700	6000	81
AM6TW-2409SH60-NZ	9-36	9	667	1800	6000	83
AM6TW-2412SH60-NZ	9-36	12	500	1000	6000	84
AM6TW-2415SH60-NZ	9-36	15	400	680	6000	85
AM6TW-2424SH60-NZ	9-36	24	250	470	6000	84
AM6TW-4805SH60-NZ	18-75	5	1200	2700	6000	81
AM6TW-4809SH60-NZ	18-75	9	667	1800	6000	83
AM6TW-4812SH60-NZ	18-75	12	500	1000	6000	84
AM6TW-4815SH60-NZ	18-75	15	400	680	6000	85
AM6TW-4824SH60-NZ	18-75	24	250	470	6000	84

**Models**  
**Dual output**

Model	Input Voltage (V)	Output Voltage (V)	Output Current max (mA)	Max. Capacitive Load (μF)	Isolation (VDC)	Efficiency (%)
AM6TW-2405D-NZ	9-36	±5	±600	±680	1500	83
AM6TW-2412D-NZ	9-36	±12	±250	±330	1500	87
AM6TW-2415D-NZ	9-36	±15	±200	±220	1500	88
AM6TW-4805D-NZ	18-75	±5	±600	±680	1500	83
AM6TW-4812D-NZ	18-75	±12	±250	±330	1500	87
AM6TW-4815D-NZ	18-75	±15	±200	±220	1500	88
AM6TW-2405DH30-NZ	9-36	±5	±600	±680	3000	82
AM6TW-2412DH30-NZ	9-36	±12	±250	±330	3000	86
AM6TW-2415DH30-NZ	9-36	±15	±200	±220	3000	87

**Input Specifications**

Parameters	Nominal	Typical	Maximum	Units
Voltage range	24 Vin 48 Vin	9-36 18-75		VDC
Absolute Maximum Input Voltage (1 Sec max)	24 Vin 48 Vin		-0.7 - 50 -0.7 - 100	VDC
Filter	π (Pi) Network			
Reflected Input ripple current		20		mA p-p
Input Under Voltage lockout	24 Vin 48 Vin	5.5 - 6.5 14.0 - 15.5		VDC
Startup time		10		ms

**Isolation Specifications**

Parameters	Conditions	Typical	Maximum	Units
Tested I/O voltage	60 sec, <1mA	1500, 3000 & 6000		VDC
Resistance		> 1000		MOhm
Capacitance	1500 & 3000VDC isolated models 6000VDC isolated models	1000 13		pF

**Output Specifications**

Parameters	Conditions	Typical	Maximum	Units
Voltage accuracy		±3		%
Balanced Load	Dual output models	±1		%
Over Voltage Protection			110 to 160	% of Vout
Short Circuit protection	Continuous Auto-recovery			
Short circuit restart				
Over Current Protection	1500 & 3000VDC isolated models 6000VDC isolated models		110 to 190 110 to 260	% of Iout
Line voltage regulation		±0.5		%
Load voltage regulation	5% to 100% load	±0.5		%
Cross voltage regulation 1500VDC Isolation	50% main load, secondary 10 to 100% load		±0.5	%
Cross voltage regulation 3000VDC Isolation	50% main load, secondary 10 to 100% load		±5	%
Temperature coefficient		±0.03		%/°C
Ripple & Noise		120		mV p-p
Transient Recovery Time	25% Load Step Change	300		μS
Transient Response Deviation	25% Load Step Change	±5		%

### General Specifications

Parameters	Conditions	Typical	Maximum	Units
Switching frequency		300		KHz
Operating temperature	Derating above +71	-40 to +85		°C
Storage temperature		-55 to +125		°C
Max Case temperature			100	°C
Cooling	Free air convection			
Humidity			95	% RH
Soldering Temperature	1.5mm from lead for 10 sec.		300	°C
Case material	1500VDC Isolated models	Aluminum Alloy		
	3000 & 6000VDC Isolated models	Black flame-retardant heat-proof plastic		
Weight	1500VDC Isolated models	14		g
	3000 & 6000VDC Isolated models	13		
Dimensions (L x W x H)	1500VDC Isolated models	1.26 x 0.79 x 0.42 inches	32 x 20.00 x 10.80 mm	
	3000 & 6000VDC Isolated models	1.24 x 0.80 x 0.40 in	31.60 x 20.30 x 10.20 mm	
MTBF	>1 000 000hrs(MIL-HDBK -217F, Ground Benign, t=+25°C)			

NOTE: All specifications in this datasheet are measured at an ambient temperature of 25°C, humidity<75%, nominal input voltage and at rated output load unless otherwise specified.

### Environment Specifications

Test	Parameters	Conditions
Vibration	Test mode	10-55Hz, speed 0.05Hz/s
	Acceleration	10g, 30min, every axis tested
	Converter operation	Before and after test, body mounted (on chassis)

### Safety Specifications

Parameters	Standards
Standards	EN55022, class A, (see the recommended EMC circuits)
	IEC61000-4-2 (ESD, contact ±4KV) Criteria B
	IEC61000-4-3 (Radiated immunity, 10V/m) Criteria A
	IEC61000-4-4 (EFT, ±2KV) Criteria B, (see the recommended EMC circuits)
	IEC61000-4-5(Surge, ±2KV) Criteria B, (see the recommended EMC circuits)
	IEC61000-4-6(CS, 3Vrms) Criteria A
	IEC61000-4-29(IVDDSI, 0-70%) Criteria B

### Pin Out Specifications

Pin	1500VDC & 3000VDC	
	Single	Dual
2	-V Input	-V Input
3	-V Input	-V Input
9	No pin	Common
11	N.C.	-V Output
14	+V Output	+V Output
16	-V Output	Common
22	+V Input	+V Input
23	+V Input	+V Input

### Dimensions 1500VDC Isolated models

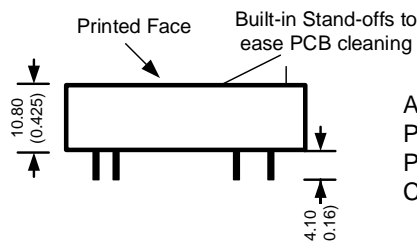
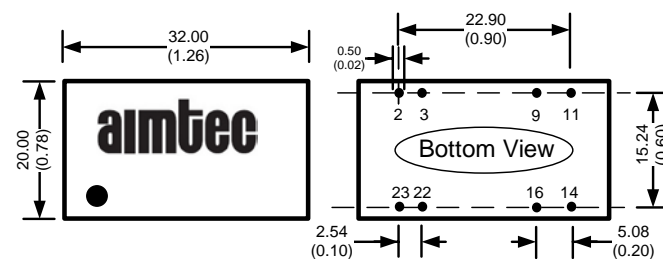

All dimensions are typical: millimeters (inches)  
Pin Diameter: 0.50 ± 0.05 (0.02 ± 0.002)  
Pin Pitch Tolerance: ± 0.35 (±0.014)  
Case Tolerance: ± 0.5 (±0.02)

### 3000VDC Isolated models

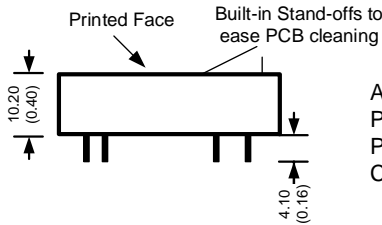
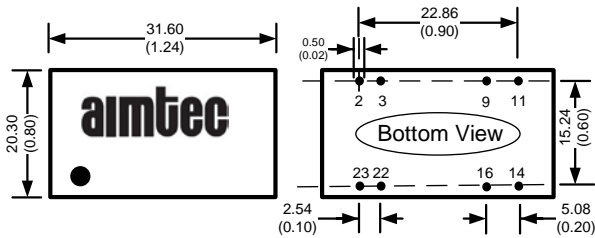

All dimensions are typical: millimeters (inches)  
 Pin Diameter:  $0.50 \pm 0.05$  ( $0.02 \pm 0.002$ )  
 Pin Pitch Tolerance:  $\pm 0.35$  ( $\pm 0.014$ )  
 Case Tolerance:  $\pm 0.5$  ( $\pm 0.02$ )

### Pin Out Specifications

Pin	6000VDC
	Single
1	+V Input
11	No Pin
12	-V Output
13	+V Output
15	No Pin
23/24	-V Input

### Dimensions 6000VDC Isolated models

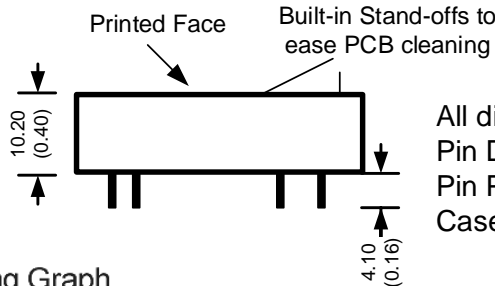
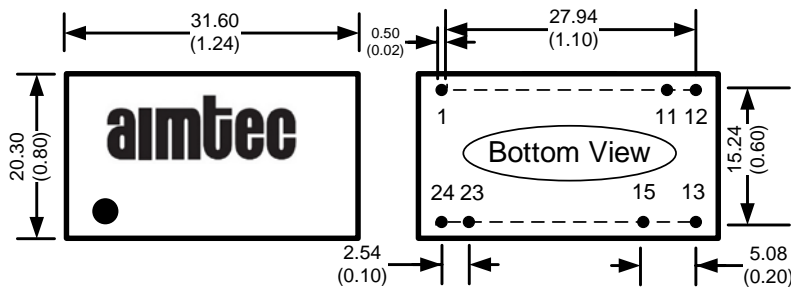

All dimensions are typical: millimeters (inches)  
 Pin Diameter:  $0.50 \pm 0.05$  ( $0.02 \pm 0.002$ )  
 Pin Pitch Tolerance:  $\pm 0.35$  ( $\pm 0.014$ )  
 Case Tolerance:  $\pm 0.5$  ( $\pm 0.02$ )

### Derating curve

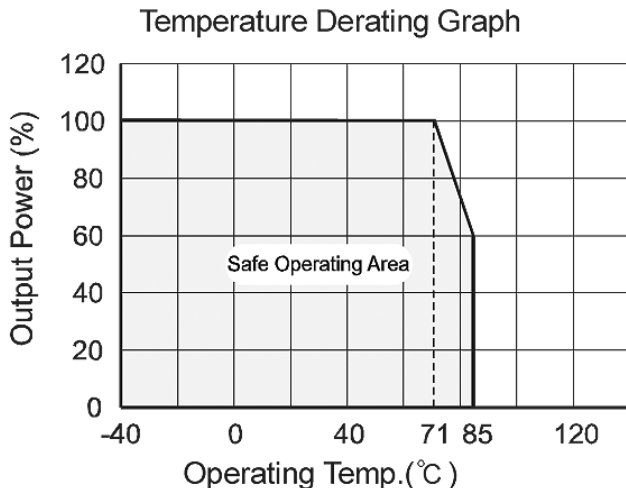

**Recommended EMC Circuit 1500VDC isolated models and 3000VDC dual output models**

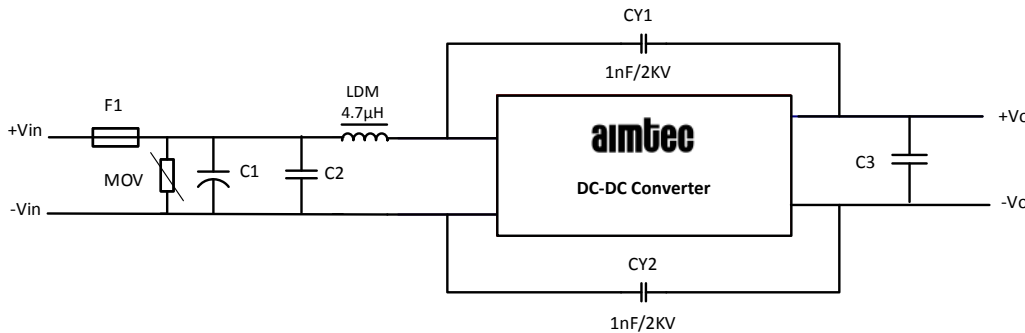

	24V input	48V input
MOV	S14K35	S14K60
C1	330µF/50V	330µF/100V
C2	1µF/50V	1µF/100V
C3	10µF/50V	10µF/100V

**Recommended EMC Circuit 3000VDC single output models**

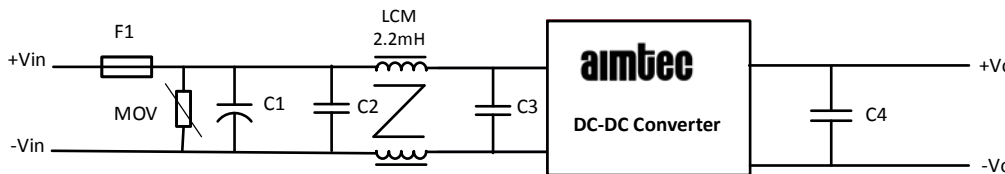

	24V input	48V input
MOV	S14K35	S14K60
C1	330µF/50V	330µF/100V
C2,C3	2.2µF/50V	2.2µF/100V
C4	10µF/50V	10µF/100V

**Recommended EMC Circuit 6000VDC isolated models**

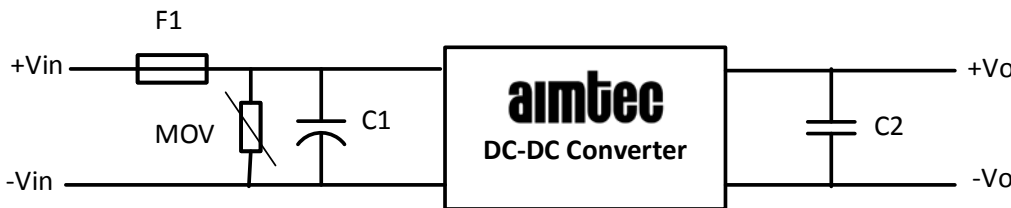

	24V input	48V input
MOV	S14K35	S14K60
C1	330µF/50V	330µF/100V
C2	10µF/50V	10µF/100V

**Recommended Circuit 6000VDC isolated models for class B compliance**

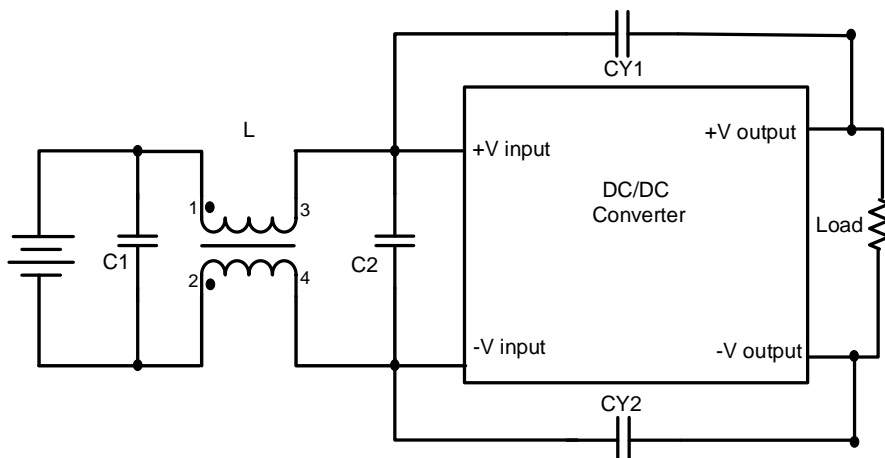

CY1, CY2	1nF/400VAC
C1,C2	2.2µF/50V
L1	2.2mH

**NOTE:** 1. Datasheets are updated as needed and as such, specifications are subject to change without notice. Once printed or downloaded, datasheets are no longer controlled by Aimtec; refer to [www.aimtec.com](http://www.aimtec.com) for the most current product specifications. 2. Product labels shown, including safety agency certifications on labels, may vary based on the date manufactured. 3. Mechanical drawings and specifications are for reference only. 4. All specifications are measured at an ambient temperature of 25°C, humidity<75%, nominal input voltage and at rated output load unless otherwise specified. 5. Aimtec may not have conducted destructive testing or chemical analysis on all internal components and chemicals at the time of publishing this document. CAS numbers and other limited information are considered proprietary and may not be available for release. 6. This product is not designed for use in critical life support systems, equipment used in hazardous environments, nuclear control systems or other such applications which necessitate specific safety and regulatory standards other the ones listed in this datasheet. 7. Warranty is in accordance with Aimtec's standard Terms of Sale available at [www.aimtec.com](http://www.aimtec.com).