

# PLED-T-xxxLF



## PMLEDT-SERIES

Rev.04-2009

- ✓ DIP16 Package
- ✓ **Step-Down Converter**
- ✓ **Constant Current**
- ✓ **High Efficiency**
- ✓ **Dimming Function**
- ✓ **Remote Control**

The PLED-T-xxxLF is a high efficiency step-down converter optimized to drive high current LEDs. The control algorithm allows highly efficient and accurate LED current regulation. The device operates from 7VDC up to 30VDC and provides an externally adjustable output current and output power up to 24 Watts. Compact DIP16 size allows designers to integrate this driver together with LED module. UL-94V0 grade molded case with high grade filling material provide excellent fire proof characters. Suitable also in mobile lighting system.

All specifications typical at Ta=25°C, nominal input voltage and full load unless otherwise specified

### Input Specifications

Voltage Range	7 – 30 VDC wide input
Input Filter	Capacitor

### Output Specifications

Voltage (Vin: 30V)	2 – 28 VDC
Current (Vin-Vout > 2V to 3V)	See table
Short Circuit Protection	Reg. at Rated Output Current
Ripple and Noise (20MHz limited)	250 mV p-p, max. (1000mA-300mV p-p, max.)

### General Specifications

Efficiency	See Table, typ.
Operating Frequency	See Table
Capacitive Load	47 uF, max.
Humidity	95% rel H
Reliability Calculated MTBF (MIL-HDBK-217F)	> 4.7 Mhrs

### Physical Specifications

Case Material	Black Plastic (with Non-Conductive Base)
Potting Material	Silicon (UL94V-0 rated)
Weight	~ 6.2g, typ.

### Environment Specifications

Operating Temperature	-40 to +85 °C (for 100%) -40 to +71 °C (PLED-T-1000LF) (for 100%)
Maximum Case Temperature	100 °C
Storage Temperature	-40 to +125 °C
Cooling	Free Air Convection
Thermal Impedance (Free Air Convection)	40 °C / W (500mA), 50 °C / W (others)
Temperature Coefficient	± 0.05%/°C, max. (1000mA: ± 0.08%/C°,max.)
RoHS conform	Soldering 260 °C, 10sec. max.

# Selection Guide

Order #	Input Voltage (VDC)	Output Voltage (VDC)	Output Current (mA)	Operating Frequency (kHz)	Efficiency (%)
PLED-T-500LF	7-30	2-28	500 ±6%	70 - 330	95
PLED-T-600LF	7-30	2-28	600 ±7%	55 - 320	95
PLED-T-700LF	7-30	2-28	700 ±7%	55 - 320	95
PLED-T-1000LF	7-30	2-28	1000 ±7%	50 - 300	95

If you need other specifications, please ask.

## Package / Pinning / Derating

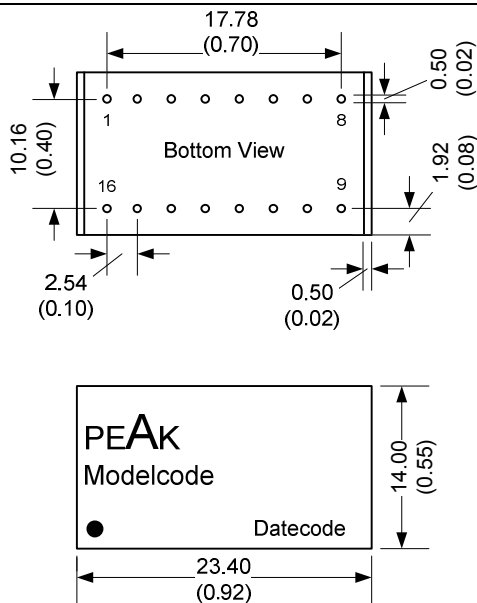

All dimensions are typical in millimeters (inches).  
 - Pin diameter: 0.5 +/-0.05 (0.02 +/-0.002)  
 - Pin pitch tolerance: +/-0.35 (+/-0.014)  
 - Case tolerance +/-0.5 (+/-0.02)  
 Specification may change without notice.

### DIP16 – PLASTIC CASE

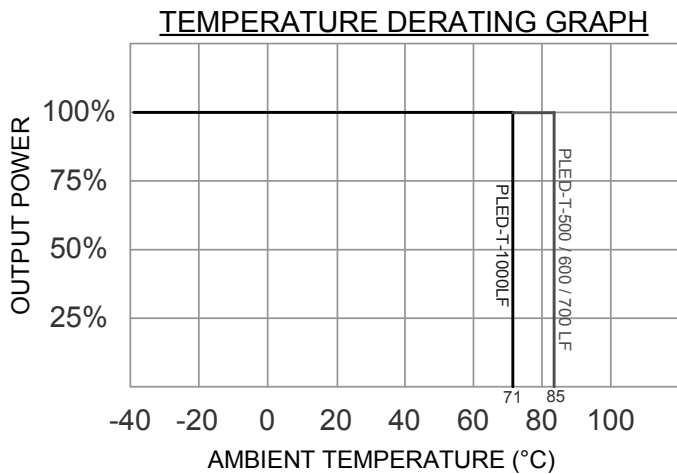

PIN CONNECTIONS	
#	SINGLE
1, 2	- Vin
3	PWM/ON/OFF
7, 8	- LED
9, 10	+ LED
15, 16	+ Vin
Others	Omitted

No connection between input and output is allowed!

# App Notes

## PWM DIMMING AND REMOTE ON/OFF CONTROL:

( Leave it open if not used.)

DC ON: Open or  $0.3V < V_{adj} < 1.25V$

DC OFF:  $V_{adj} < 0.15V$  (Shutdown)

Max. Remote Pin Drive Current: **1 mA**

Max. Quiescent Input Current in Shutdown Mode ( $V_{in}=30V$ ) **25 uA**

Recommended max. Operation Frequency: **1 KHz**

Min. Switch ON / OFF Time: **200 ns**

## ANALOG DIMMING CONTROL:

Input Voltage Range: 0.3V to 1.25V

Control Voltage Limits

ON: 0.2V – 0.3V

OFF: 0.15V – 0.25V

Max. Analog Pin Drive Current ( $V_{adj} = 1.25V$ ): **1 mA**

### Note:

1.Note about the polarity of input power , reversed power supply may damage the circuit.

2.Leave the pin  $V_{ADJ}$  opened while not in use , Grounded can shut the driver off and connect to  $V_{in}$  Power may burn the circuit.

## Recommended additional input filter:

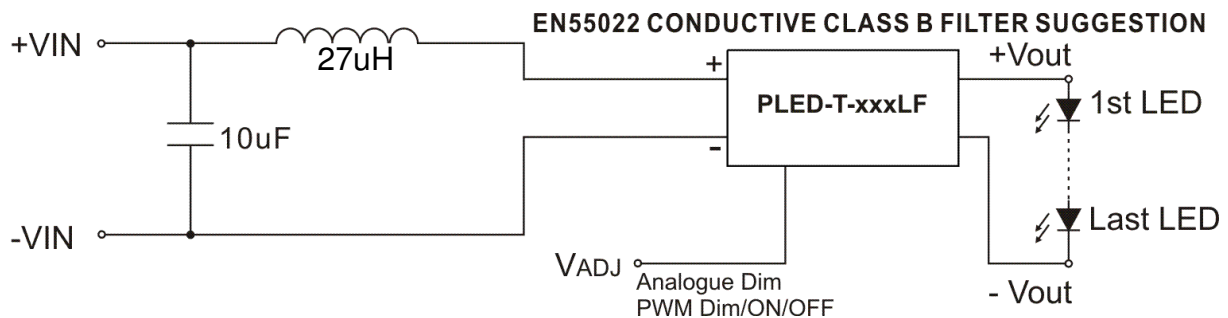

# App Notes

## Typical application:

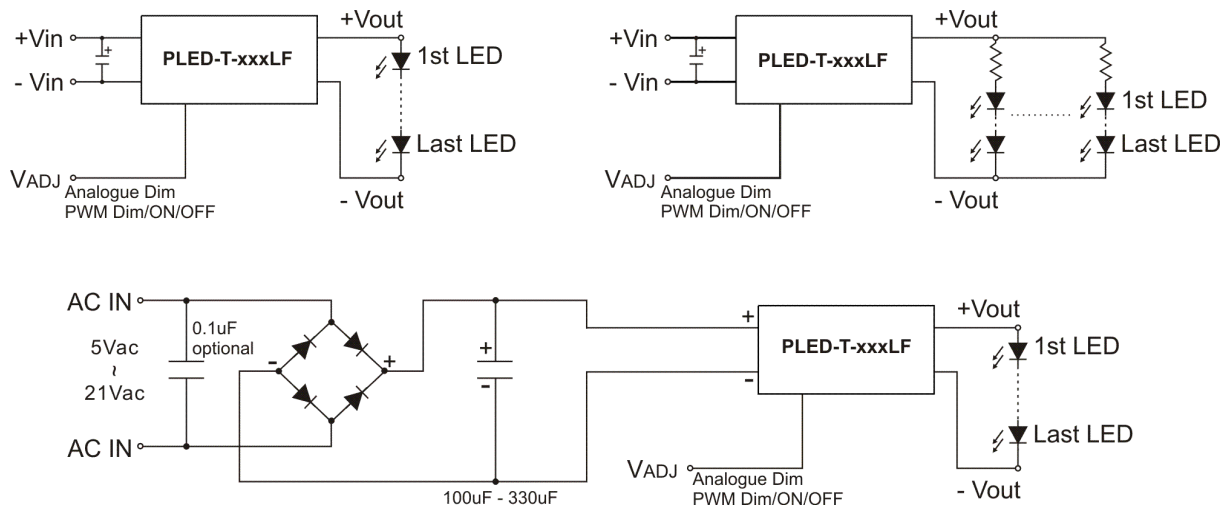

## Output current adjustment by external DC control voltage:

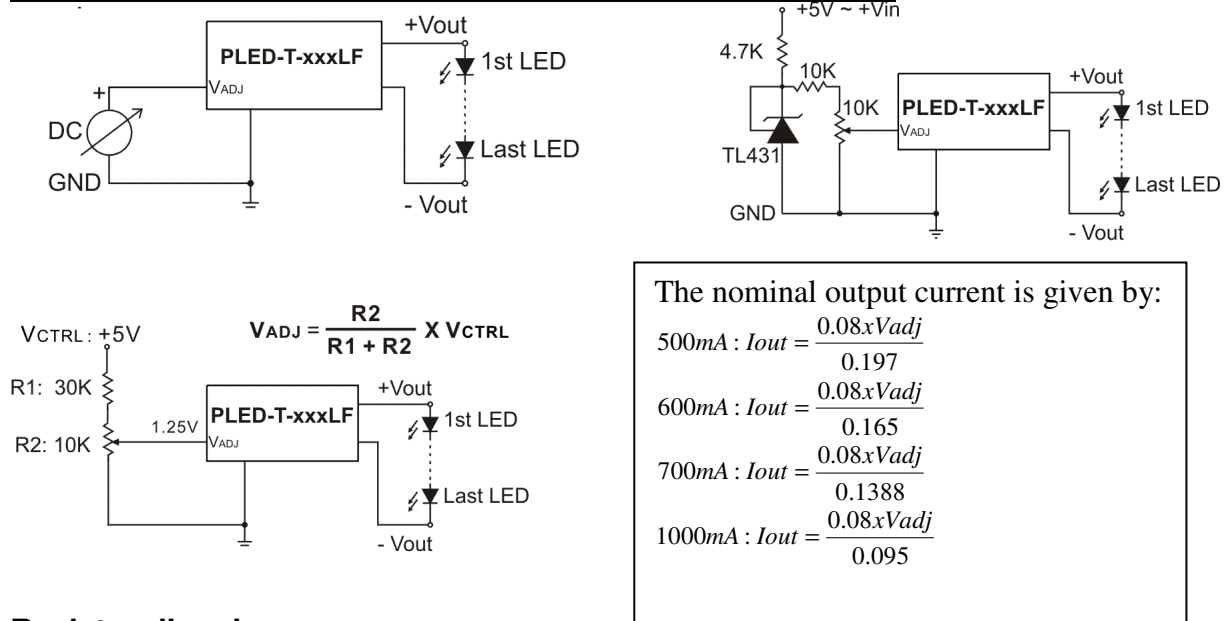

The nominal output current is given by:

500mA	$I_{out} = \frac{0.08 \times V_{adj}}{0.197}$
600mA	$I_{out} = \frac{0.08 \times V_{adj}}{0.165}$
700mA	$I_{out} = \frac{0.08 \times V_{adj}}{0.1388}$
1000mA	$I_{out} = \frac{0.08 \times V_{adj}}{0.095}$

## Resistor dimming:

By connecting a variable resistor between ADJ and GND, simple dimming can be achieved. Capacitor Cadj is optional for better AC mains interference and HF noise rejection. Recommend value of Cadj is 0.22uF.

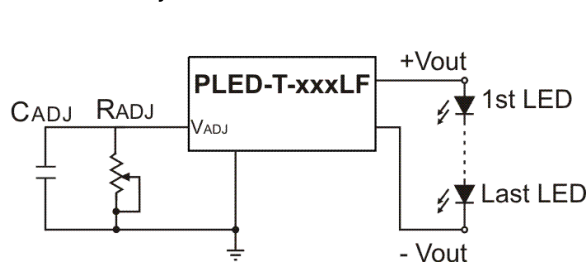

The output current can be determined using the equation:

500mA	$I_{out} = \frac{(0.08/0.197) \times R_{adj}}{(R_{adj} + 200k)}$
600mA	$I_{out} = \frac{(0.08/0.165) \times R_{adj}}{(R_{adj} + 200k)}$
700mA	$I_{out} = \frac{(0.08/0.1388) \times R_{adj}}{(R_{adj} + 200k)}$
1000mA	$I_{out} = \frac{(0.08/0.095) \times R_{adj}}{(R_{adj} + 200k)}$

# App Notes

## Output current adjustment by PWM control:

### Directly driving ADJ input

A pulse width modulated (PWM) signal with duty cycle DPWM can be applied to the ADJ pin, as shown below:

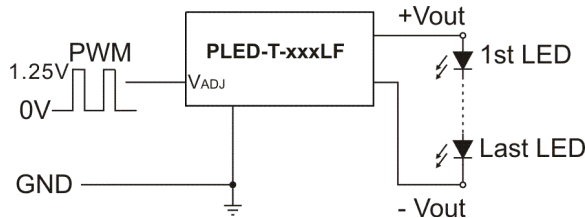

500mA : $I_{out} = \frac{0.1D_{pwm}}{0.197}$	[for $0 < D_{pwm} < 1$ ]
600mA : $I_{out} = \frac{0.1D_{pwm}}{0.165}$	[for $0 < D_{pwm} < 1$ ]
700mA : $I_{out} = \frac{0.1D_{pwm}}{0.1388}$	[for $0 < D_{pwm} < 1$ ]
1000mA : $I_{out} = \frac{0.1D_{pwm}}{0.095}$	[for $0 < D_{pwm} < 1$ ]

The diode and resistor suppress possible high amplitude negative spikes on the ADJ input resulting from the drain-source capacitance of the FET. Negative spikes at the input to the device should be avoided as they may cause errors in output current or erratic device operation.

### Driving the ADJ input via open collector transistor

The diode and resistor suppress possible high amplitude negative spikes on the ADJ input resulting from the drain-source capacitance of the transistor. Negative spikes at the input to the device should be avoided as they may cause errors in output current, or erratic device operation.

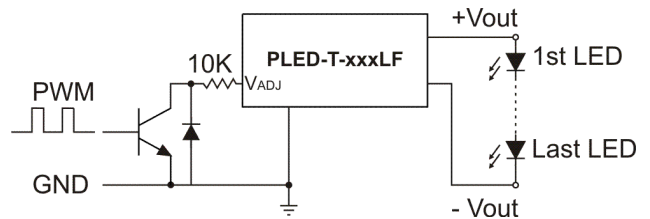

### Driving the ADJ input from a microcontroller:

Another possibility is to drive the device from the open drain output of a microcontroller. The diagram below shows one method of doing this:

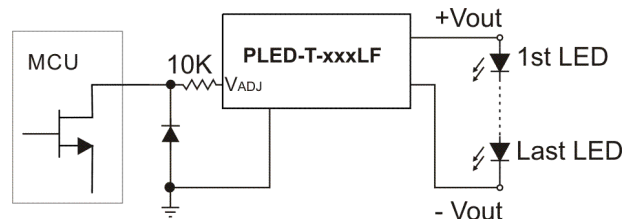

## Output current adjustment by PWM control (Dimming):

To avoid visible flicker the PWM signal must be greater than 100Hz.

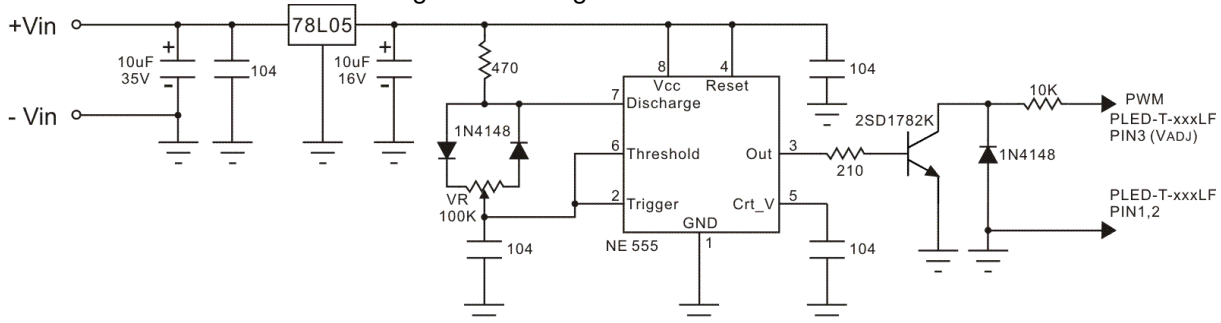

## Output current adjustment by PWM control (Flash):

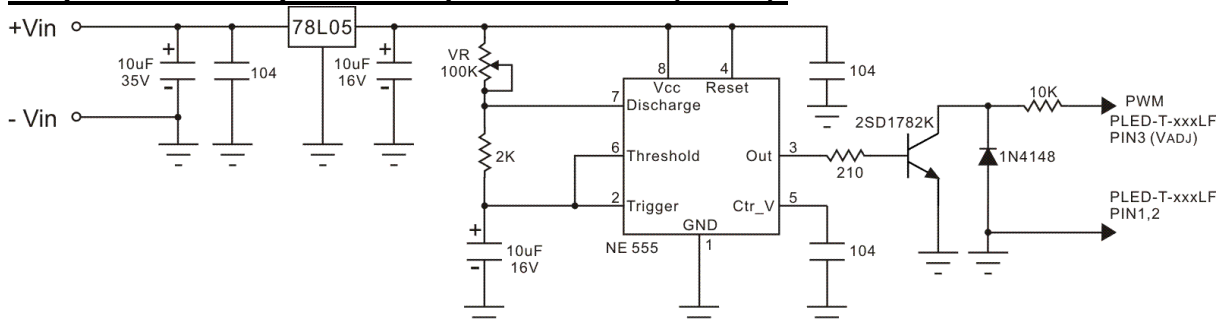

# App Notes

## Output current adjustment by external DC control voltage:

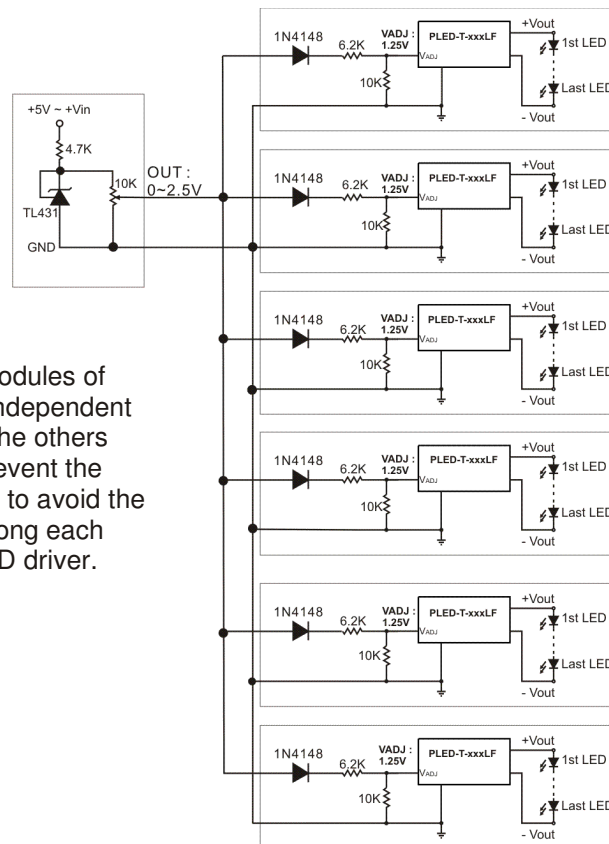

**NOTE:**

In this application, the LED modules of each LED drivers should be independent from electrical connection to the others and input power - this is to prevent the damaging to LED drivers also to avoid the unnecessary interference among each LED module driven by the LED driver.

## Thermal feedback circuit:

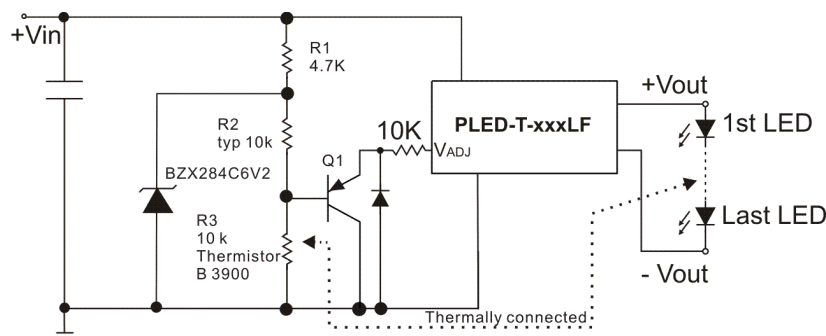

The selection of components for the thermal feedback circuit is not only dependent on the choice of R2 and R3, but also on the amount of heat sink area required to extract heat from the LEDs. To maximize the light output at high ambient or operating temperature conditions, the LEDs must have a sufficient thermal

extraction path otherwise the thermal control circuit will effect current drive reduction in non-optimal conditions. The thermal control threshold point is set by adjusting R2. For this design, three values (33k, 22k and 10k) were evaluated. These values were chosen to give break points at approximately 25°C, 40°C and 60°C. Note that the light output will not continually dim to zero - the thermal control is applying DC control to the ADJ pin and therefore has a dimming ratio from maximum current of approximately 5:1. Once the reduced DC level goes below the shutdown threshold of around 200mV, the LED drive current will fall to zero and the LEDs will be extinguished. The slope of the current reduction is determined by the beta value of the thermistor. The larger the beta value, the sharper will be the resultant current control response. The slope of the current reduction is also affected by Q1's base emitter voltage (VBE) variation with temperature.