

FEATURES

- ◆Footprint over pins 1.37cm²
- ◆Short Circuit Protection(automatic recovery)
- ◆I/O isolation voltage 1000VDC
- ◆Operating Temperature: -40℃ ~ + 85℃
- ◆High efficiency up to 78%
- ◆Toroidal magnetics
- ◆Small SMD package with footprint
- ◆Power density 1.8W/cm³
- ◆Lead frame technology
- ◆Multi-layer ceramic capacitors
- ◆Custom solutions available

MODEL SELECTION

B^①05^②05^③N^④X^⑤T^⑥-1W^⑦

- ① Product Series
- ② Input Voltage
- ③ Output Voltage
- ④ No Pin
- ⑤ Fixed Input
- ⑥ SMD Package
- ⑦ Rated Power

APPLICATIONS

The B-NXT-1W series are miniature, 1W DC/DC converters with high isolation in a SMD package. With a new package design these converters are qualified for the higher temperatures requested by lead-free reflow solder processes. With the small footprint, these converters are the ideal solution for board level power distribution, mainly for applications in the industrial and telecom field. For automated SMD production lines the devices can be supplied in standard tape and reel package.



CE REACH
MICRODC RESERVES THE COPYRIGHT

SELECTION GUIDE

Order code	Input		Output		Efficiency (% Typ.)	Isolation	MTTF ¹
	Voltage(VDC)	Current (mA)	Voltage (VDC)	Current (mA)		Capacitance	
	Nominal	Rated Load			pF	KHrs	
B0303NXT-1W	3.3	410	3.3	303	81	29	5348
B0305NXT-1W	3.3	390	5	200	83	30	3847
B0309NXT-1W	3.3	400	9	111	74	34	3134
B0312NXT-1W	3.3	400	12	83	76	40	3473
B0315NXT-1W	3.3	400	15	66	81	42	2473
B0503NXT-1W	5	270	3.3	303	85	31	5515
B0505XT-1W	5	294	5	200	83	33	6857
B0505NXT-1W	5	260	5	200	86	42	3933
B0506NXT-1W	5	278	6	167	83	43	6677
B0509NXT-1W	5	267	9	111	85	38	5501
B0512NXT-1W	5	260	12	83	74	44	3957
B0515NXT-1W	5	256	15	66	78	43	2747
B1205NXT-1W	12	124	5	200	80	50	4683
B1209NXT-1W	12	114	9	111	80	72	4008
B1212NXT-1W	12	113	12	83	85	89	3121
B1215NXT-1W	12	111	15	66	81	100	2316

1. Calculated using MIL-HDBK-217FN2 with nominal input voltage at full load.
All specifications typical at TA=25℃, nominal input voltage and rated output current unless otherwise specified.

Input Characteristics

Parameter	Conditions	Min.	Typ.	Max.	Units
Voltage range	Continuous operation, 3.3V input	2.97	3.3	3.63	VDC
	Continuous operation, 5V input	4.5	5	5.5	VDC
	Continuous operation, 12V input	10.8	12	13.2	VDC
Start up time			30	47	mA p-p

Isolation Characteristics

Parameter	Conditions	Min.	Typ.	Max.	Units
Isolation voltage	Flash tested for 1 second	1000			VDC
Resistance	Viso= 1000VDC	10			GΩ

General Characteristics

Parameter	Conditions	Min.	Typ.	Max.	Units
Switching frequency	All output types		110		kHz

Absolute Maximum Ratings

Parameter	Conditions
Lead temperature 1.5mm from case for 10 seconds	300℃
Internal power dissipation	600mW
Input voltage V, B03 types	5.5V
Input voltage Vin, B05 types	7V
Input voltage Vin, B12 types	15V

Output Specifications

Parameter	Conditions	Min.	Typ.	Max.	Units
Rated Power	TA=-40°C to 85°C	0.1		1.0	W
Voltage Set Point	See tolerance envelope				
Line regulation	High VIN to low VIN		1.0	1.2	%%
Load regulation ¹	10% load to rated load, 0303& 0503		10	14	%
	10% load to rated load, 0505& 1205		12.8	15	%
	10% load to rated load, 0506		9.2	10	%
	10% load to rated load, 0509 & 1209		8.3	9.0	%
	10% load to rated load, 0512& 1212		6.8	7.5	%
	10% load to rated load, 0515& 1215		6.3	7.0	%
Ripple & Noise	BW=DC to 20MHz, 3.3V output types, 0305 & 0505		40	60	mV p-p
	BW=DC to 20MHz, 3.3V output types, 0505 & 1205		62	85	mV p-p
	BW=DC to 20MHz, 0506		103	170	mV p-p
	BW=DC to 20MHz, 0509& 1209		49	75	mV p-p
	BW=DC to 20MHz, 0512& 1212		39	65	mV p-p
	BW=DC to 20MHz, 0515& 1215		38	76	mV p-p

Note:1. 12V input types have typically 3% less load regulation change.

Temperature Characteristics

Parameter	Conditions	Min.	Typ.	Max.	Units
Specification	All output types	-40		85	°C
Storage		-55		125	°C
Case temperature rise above ambient	0305, 0309, 0315		25		°C
	0303, 0312, 0503, 0505, 0509, 0512C, 0515		30		°C
	0505, 1205		43		°C
	1209, 1212, 1215		40		°C
Cooling	Free air convection				

Technical notes

ISOLATION VOLTAGE

'Hi Pot Test', 'Flash Tested', 'Withstand Voltage', 'Proof Voltage', 'Dielectric Withstand Voltage' & 'Isolation Test Voltage' are all terms that relate to the same thing, a test voltage, applied for a specified time, across a component designed to provide electrical isolation, to verify the integrity of that isolation.

Professional Power Module B-NXT-1W series of DC/DC converters are all 100% production tested at their stated isolation voltage. This is 1kVDC for 1 second.

A question commonly asked is, "What is the continuous voltage that can be applied across the part in normal operation?"

For a part holding no specific agency approvals, such as the B-NXT-1W series, both input and output should normally be maintained within SELV limits i.e. less than 42.4V peak, or 60VDC. The isolation test voltage represents a measure of immunity to transient voltages and the part should never be used as an element of a safety isolation system. The part could be expected to function correctly with several hundred volts offset applied continuously across the isolation barrier; but then the circuitry on both sides of the barrier must be regarded as operating at an unsafe voltage and further isolation/insulation systems must form a barrier between these circuits and any user-accessible circuitry according to safety standard requirements.

REPEATED HIGH-VOLTAGE ISOLATION TESTING

It is well known that repeated high-voltage isolation testing of a barrier component can actually degrade isolation capability, to a lesser or greater degree depending on materials, construction and environment. The B-NXT-1W series has toroidal isolation transformers, with no additional insulation between primary and secondary windings of enameled wire. While parts can be expected to withstand several times the stated test voltage, the isolation capability does depend on the wire insulation. Any material, including this enamel (typically polyurethane) is susceptible to eventual chemical degradation when subject to very high applied voltages thus implying that the number of tests should be strictly limited. We therefore strongly advise against repeated high voltage isolation testing, but if it is absolutely required, that the voltage be reduced by 20% from specified test voltage.

This consideration equally applies to agency recognized parts rated for better than functional isolation where the wire enamel insulation is always supplemented by a further insulation system of physical spacing or barriers.

Temperature derating graph

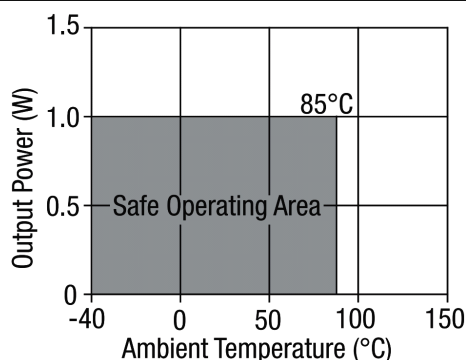

Application Notes

Minimum load

The minimum load to meet datasheet specification is 10% of the full rated load across the specified input voltage range. Lower than 10% minimum loading will result in an increase in output voltage, which may rise to typically double the specified output voltage if the output load falls to less than 5%.

Capacitive loading and start up

Typical start up times for this series, with a typical input voltage rise time of 2.2 μ s and output capacitance of 10 μ F, are shown in the table below. The product series will start into a capacitance of 47 μ F with an increased start time, however, the maximum recommended output capacitance is 10 μ F.

Start-up time		Start-up time	
μ s		μ s	
B0303NXT	437	B0506NXT	7200
B0305NXT	1359	B0509NXT	3146
B0309NXT	3435	B0512NXT	4960
B0312NXT	6590	B0515NXT	7740
B0315NXT	7625	B1205NXT	895
B0503NXT	533	B1209NXT	2150
B0505XT	1368	B1212NXT	3640
B0505NXT	721	B1215NXT	7180

Typical Start-Up Wave Form

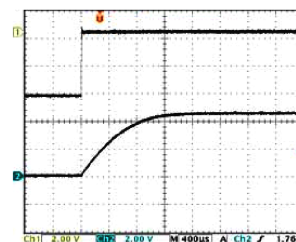

Ripple & Noise Characterization Method

Ripple and noise measurements are performed with the following test configuration.

C1	1 μ F X7R multilayer ceramic capacitor, voltage rating to be a minimum of 3 times the output voltage of the DC/DC converter
C2	10 μ F tantalum capacitor, voltage rating to be a minimum of 1.5 times the output voltage of the DC/DC converter with an ESR of less than 100m Ω at 100 kHz
C3	100nF multilayer ceramic capacitor, general purpose
R1	450 Ω resistor, carbon film, \pm 1% tolerance
R2	50 Ω BNC termination
T1	3T of the coax cable through a ferrite toroid
RLOAD	Resistive load to the maximum power rating of the DC/DC converter. Connections should be made via twisted wires

Measured values are multiplied by 10 to obtain the specified values.

Differential Mode Noise Test Schematic

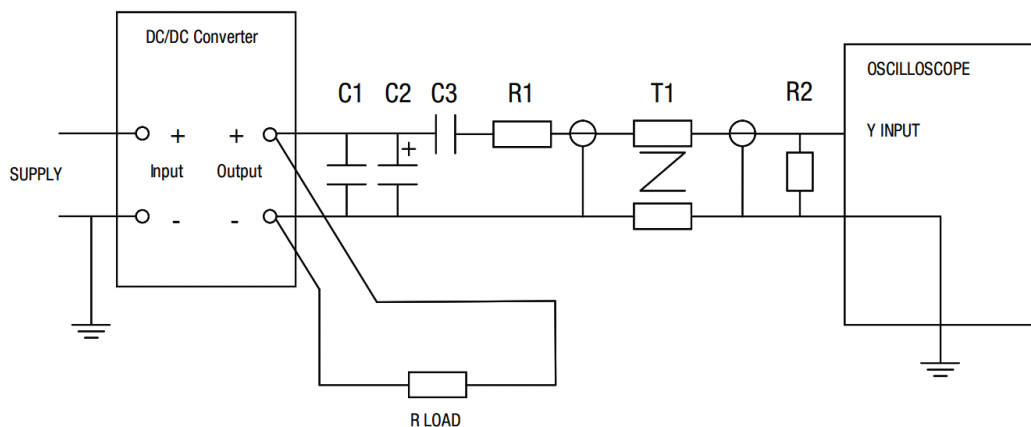

Application Notes

Output Ripple Reduction

By using the values of inductance and capacitance stated, the output ripple at the rated load is lowered to 5mV p-p max.

Component selection

Capacitor: It is required that the ESR (Equivalent Series Resistance) should be as low as possible, ceramic types are recommended.

The voltage rating should be at least twice (except for 15V output), the rated output voltage of the DC/DC converter.

Inductor: The rated current of the inductor should not be less than that of the output of the DC/DC converter. At the rated current, the DC resistance of the inductor should be such that the voltage drop across the inductor is <2% of the rated voltage of the DC/DC converter. The SRF (Self Resonant Frequency) should be >20MHz.

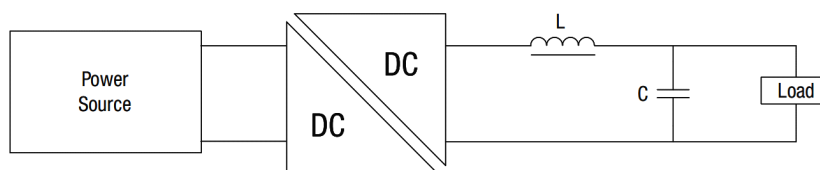

	Inductor			Capacitor
	L, μ H	SMD	Through Hole	C, μ F
B0303NXT	10	82103C	11R103C	4.7
B0305NXT	47	82473C	11R103C	4.7
B0309NXT	22	82223C	11R223C	2.2
B0312NXT	10	82103C	11R103C	1
B0315NXT	47	82473C	11R473C	1
B0503NXT	10	82103C	11R103C	4.7
B0505XT	47	82473C	11R473C	4.7
B0505NXT	47	82473C	11R473C	4.7
B0506NXT	10	82103C	11R103C	4.7
B0509NXT	22	82223C	11R223C	2.2
B0512NXT	47	82473C	11R473C	1
B0515NXT	47	82473C	11R473C	1
B1205NXT	47	82473C	11R473C	4.7
B1209NXT	22	82223C	11R223C	2.2
B1212NXT	47	82473C	11R473C	1
B1215NXT	47	82473C	11R473C	1

Tolerance Envelopes

Tolerance Envelope - 3.3V output types.

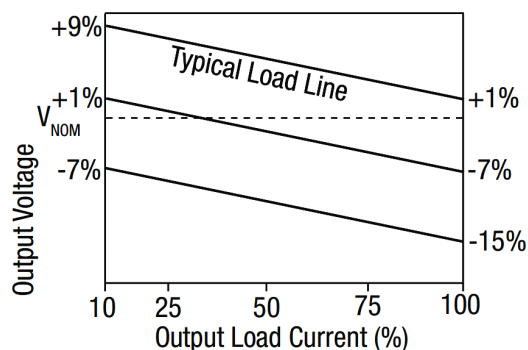

All other types.

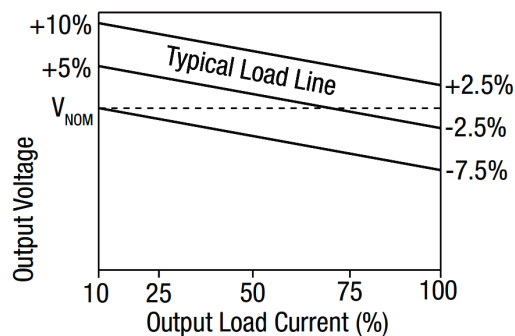

The voltage tolerance envelope shows typical load regulation characteristics for this product series. The tolerance envelope is the maximum output voltage variation due to changes in output loading.

OUTLINE DIMENSIONS & FOOTPRINT DETAILS

MECHANICAL DIMENSIONS

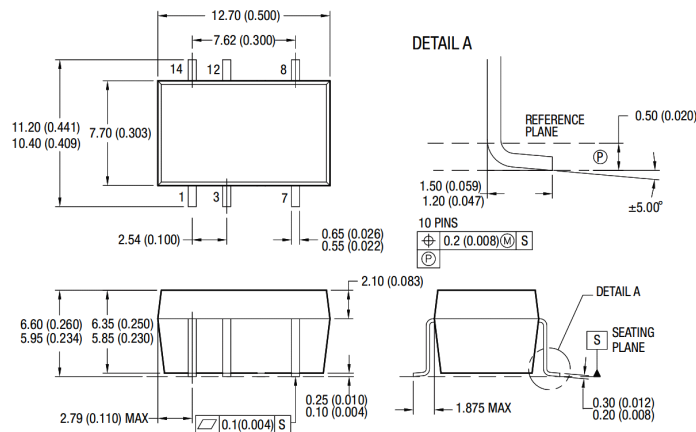

Note:
 Unit:mm[inch]
 Pin section tolerances:±0.10mm[±0.004inch]
 General tolerances:±0.25mm[±0.010inch]

Weight: 1.21g

SOLDER PAD DIMENSION

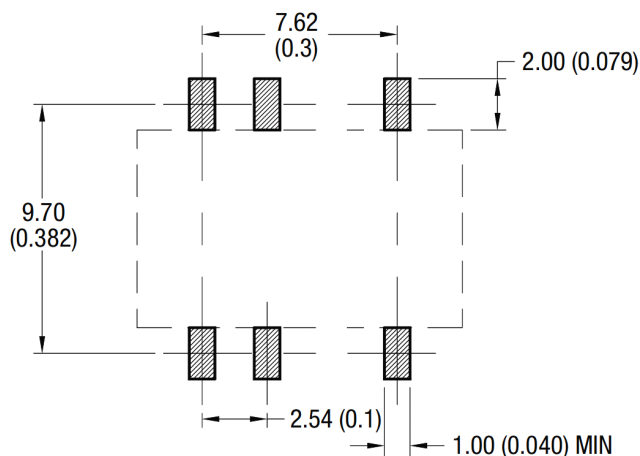

Dimensions in [mm], () = Inch
 Pin pitch tolerances: ±0.13 (±0.005)
 Other tolerances: ±0.25 (±0.01)

FOOTPRINT DETAILS

Pin	Single
1	-Vin
3	+Vin
7	-Vout
8	+Vout
12	NA
14	NA

NA - Not available for electrical connection.

TUBE OUTLINE DIMENSIONS

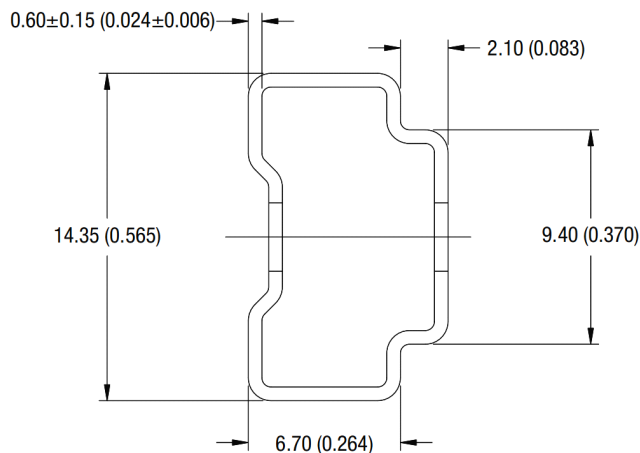

Unless otherwise stated all dimensions in mm±0.5 (inches ±0.02).
 Tube length : 475±2.0 (18.70±0.07). Tube Quantity :35

Specifications can be changed any time without notice.

No parallel connection or plug and play.

Note:

1. The load shouldn't be less than 10%, otherwise ripple will increase dramatically.
2. Operation under 10% load will not damage the converter; However, they may not meet all specification listed.
3. All specifications measured at Ta=25°C, humidity<75%, nominal input voltage and rated output load unless otherwise specified.
4. In this datasheet, all the test methods of indications are based on corporate standards.
5. Only typical models listed, other models may be different, please contact our technical person for more details.

Tape & Reel Specifications

Reel Packaging Details

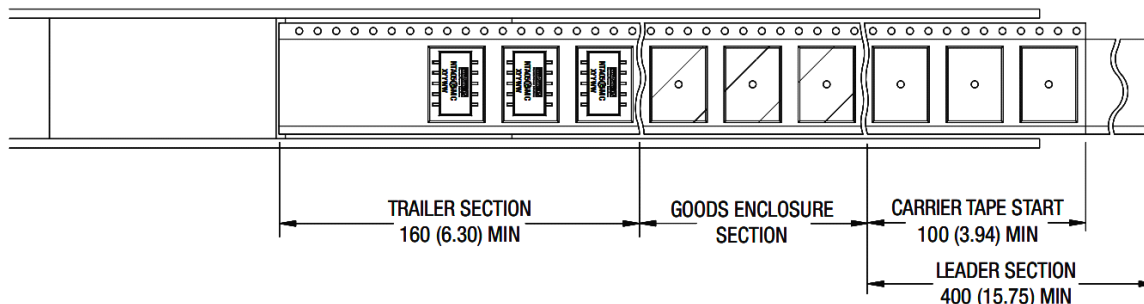

Product Orientation

Pin 1, located nearest to carrier drive sprocket.

Reel Quantity : 500

Reel Outline Dimensions

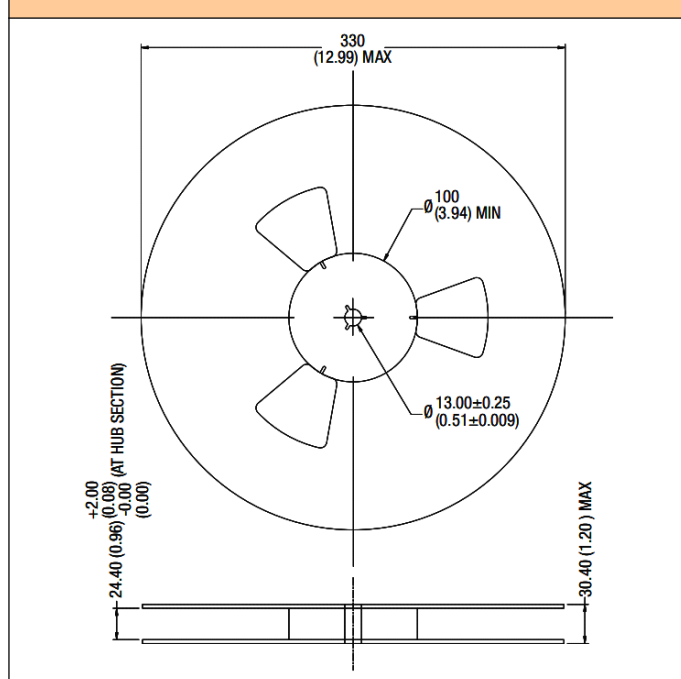

Tape Outline Dimensions

